

Optical Strain Gage | os3150

Applications

- Continuous lifetime health monitoring of bridges, dams, buildings, tunnels, ships, aircraft, trains, and other complex structures.
- Measurement of strain on a structure's surface.
- Experimental mechanics evaluations requiring many sensors.

Features

- Rugged, permanent weldable package.
- Qualified to same rigorous standards used for comparable electronic gages.
- Armored cable integrated with sensor package for fiber protection and strain relief.
- Fast, simple, repeatable installation.
- Double ended design supports multiplexing of many sensors on one fiber.
- Gage installation and protection achieved with same methods as conventional electronic gages.
- Micron Optics' patented micro opto-mechanical technology.

Description

The os3150 is a rugged strain gage based on fiber Bragg grating (FBG) technology.

Optimized for outdoor installations on steel structures, the os3150's stainless steel carrier holds the FBG in tension and protects the fiber during installation. Since there are no epoxies holding the fiber to the carrier, long term stability is ensured by design.



os3150 Optical Strain Gage

Installation time is just a few minutes. Since the gages are welded in place, they can be used immediately after attachment without waiting for adhesives to cure. Armored cables lead to and from each gage, making both installation and fiber protection fast and easy. The armored cable is compatible with connector protection fittings that protect splice-free series connections to strain, temperature, acceleration and other types of optical sensors. The entire strain gage package is typically covered with a protective material to complete installation for long term protection.



Protection Fitting

In side by side comparisons with foil strain gages, the os3150 is equally sensitive and accurate, while providing for greater strain range and 100 times more fatigue life. The os3150 strain gage is qualified for use in harsh environments and delivers the many advantages inherent to all FBG based sensors.

This sensor can be used alone or in series as a part of an FBG sensor array. Installation and cabling for such arrays is much less expensive and cumbersome than comparable electronic gage networks. Multiple optical strain gages can be arranged in close proximity at 0, 45 and 90 degrees for strain rosette measurements.

Optical Strain Gage | os3150



Specifications ¹

os3150

Performance Properties

Strain Sensitivity ²	~ 1.4 pm/με
Gage Length	75 mm
Operating Temperature Range	-40 to 80° C
Strain Limits	± 2,500 με
Fatigue Life	100 x 10 ⁶ cycles, ± 2,000 με

Physical Properties

Dimensions	See Diagram Below
Weight (without cable)	15 g
Carrier Material	302 Stainless Steel
Cable Length	1 m (± 10 cm), each end
Fiber Type	SMF28-Compatible
Cable Type	3 mm Armored Cable
Connectors	FC/APC optional
Cable Bend Radius	≥ 17 mm
Fastening Method ³	Spot Weld

Optical Properties

Peak Reflectivity (Rmax)	> 70%
FWHM (-3 dB point)	0.25 nm (± .05 nm; apodized grating)
Isolation	> 15 dB (@ ± 0.4 nm around center wavelength)

Notes:

1. Denotes Beta product. For more details see www.micronoptics.com/product_designation.php.
2. Actual gage factor provided with gage.
3. See http://www.micronoptics.com/support_downloads/Sensors/ for installation details.

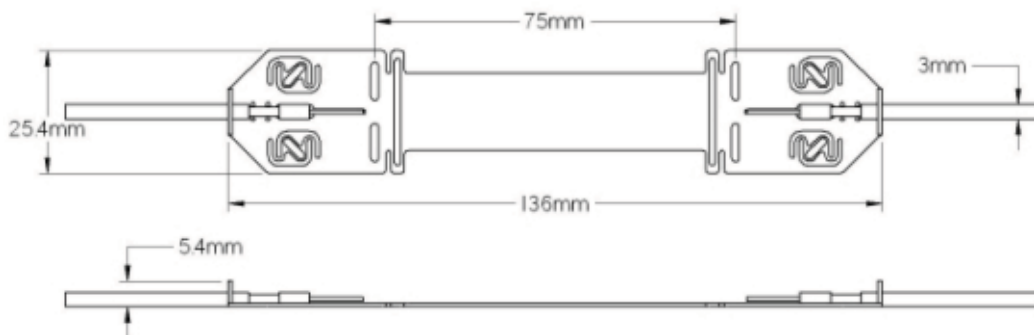

Ordering Information

os3150-**www**-1xx-1yy

(Example: os3150-1563-1FC-1FC)

www: Wavelength (±1nm)

Standard: 1515 to 1587nm in 4nm intervals.

Extended: 1460 to 1620nm

1xx: Cable 1, Length & Connector

1 1 m Standard, Cable Length

UT Underterminated

FC FC/APC Connector

PF FC/APC Connector with Protection Fitting

1yy: Cable 2, Length & Connector

1 1 m Standard, Cable Length

UT Underterminated

FC FC/APC Connector

PF FC/APC Connector with Protection Fitting



Micron Optics, Inc.
1852 Century Place NE
Atlanta, GA 30345 USA

phone 404 325 0005
fax 404 325 4082
www.micronoptics.com